

CAT Condensate Actuated Temperature Control



Design Features

- 300 psig (maximum operating pressure)
- High flow capacity
- Back pressure insensitive
- Freeze protected – self draining
- Maintains temperature set point
- 100% factory tested

Benefits

- Easy installation
- Reliable, unattended operation
- Minimal maintenance requirements
- Conserves energy
- Minimizes flash and live steam loss

Specification and Ordering Information

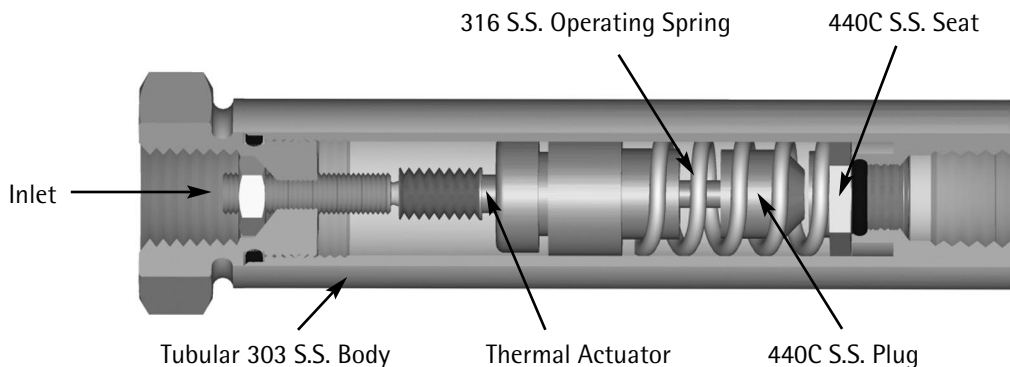

Inlet Thread NPT	Outlet Thread NPT	Maximum Operating Pressure (psig)	Cv	Standard Set Points	Weight (lbs)	Body Material
3/8" 1/2"	3/8" 1/2"	300	2	60, 100, 120 180, 240 (other set points available)	0.75	303 SS

- Flow coefficient Cv at set point
- Other temperature set points available. Consult local distributor.

Note: Not suitable for superheated steam systems

How To Order

Complete the model number by inserting the desired size (NPT) and condensate discharge temperature.

3/8 or 1/2

condensate discharge temperature

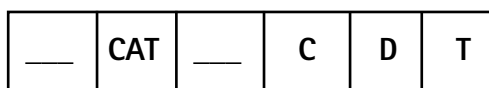

Actual temperature settings would depend upon the requirements and variables of your specific application. A 180°F setting, for example, is ideal for most winterization systems; a 240°F setting is suggested for most process tracing and drip legs. For impulse and sample lines, a 60°F or 120°F setting could be used.

Note: Valve will slowly actuate with a 15°F differential of specified setpoint.

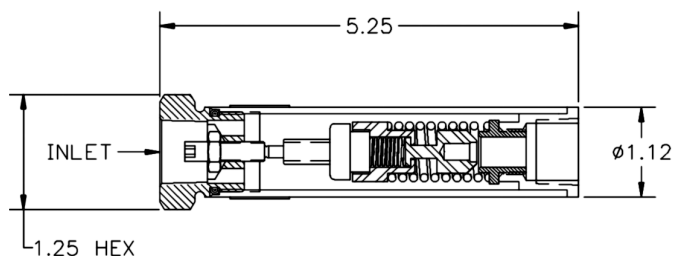

The Ogontz Guarantee

We will repair or replace on a no-charge basis, FOB Willow Grove, PA, any Ogontz product returned to us within 18 months, if found to be defective in material or workmanship.

2835 Terwood Road • Willow Grove, PA 19090 USA
800/523-2478 • 215/657-4770 • Fax: 215/657-0460
www.ogontz.com • info@ogontz.com



North America • South America • Europe • Asia
Copyright Ogontz Corporation, 2007 • Bulletin #4-07