

Bleed Valves

Features

- Pressure rating up to 10,000psig(689bar) at 100°F(37°C).
- Temperature rating from -65°F to 850°F (-54°C to 454°C) with stainless steel, from -20°F to 450°F(-29°C to 232°C) with carbon steel, from -65°F to 500°F (-54°C to 260°C) with alloy 400.
- Back stop screw prevents accidental remove of stem.
- Stem thread and tips are chrome-plated for maximum service life.
- Size range from 1/8" thru 1/2" tubing and piping system.
- Variety of end connections including Hy-Lok tube fittings, male/female NPT and ISO, SAE threads.

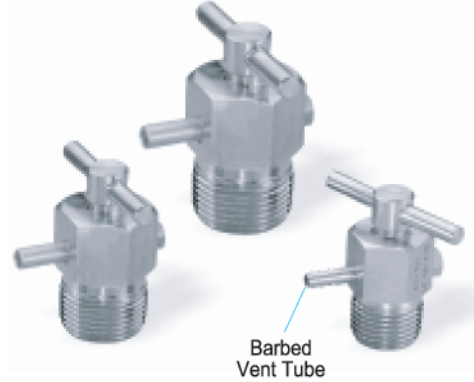

Materials of Construction

Description	Body Materials		
	Grade / ASTM Specification		
Body ①	316 SS	Carbon Steel	Alloy 400
Stem ②	316 / A479	Carbon Steel ③	400 / B164
Back Stop Screw	316 / A479		
Vent Tube	316 / A213	400 / B165	

- ① Male Straight thread(SAE) body with PFM O-ring.(e.g Viton)
- ② Chrome - Plated on thread for max. service life
- ③ Yellow zinc plated for corrosion resistance

Applications

Hy-Lok bleed valves can be used on instrumental fluid handling apparatus such as manifolds or gage/root valves in order to vent signal line pressure to atmosphere before disassemble of an instrument or to facilitate in calibration of control devices.

Test

- Each valve is tested with nitrogen @1000psig(69bar) to max leak rate of 0.1 SCCM.
- Hydrostatic shell test is performed at 1.5 times the working pressure as an option.
- Other tests are available upon request

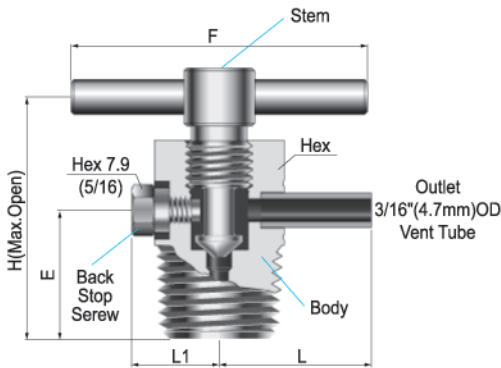

Table of Dimension

Basic Part Number	Orifice (Cv)	Inlet End Connection	Dimensions											
			E		F		H		L		L1		Hex.	
			in.	mm	in.	mm	in.	mm	in.	mm	in.	mm	in.	mm
BLV	-2N	1/8 Male NPT	0.75	19.1	2.0	50.8	1.61	41.0	0.94	23.9	0.56	14.3	5/8	15.8
	-4N	1/4 Male NPT	0.75	19.1			1.61	41.0	0.94	23.9	0.56	14.3	5/8	15.8
	-6N	3/8 Male NPT	0.87	22.1			1.73	44.0	1.03	26.1	0.59	15.1	7/8	22.2
	-8N	1/2 Male NPT	0.87	22.1			1.73	44.0	1.03	26.1	0.59	15.1	7/8	22.2
	-4U	SAE 7/16-20	0.77	19.6			1.63	41.5	1.03	26.1	0.59	15.1	7/8	22.2
	-8U	SAE 3/4-16	0.82	20.8			1.68	42.7	1.03	26.1	0.59	15.1	7/8	22.2

Dimensions are for reference only, subject to change.

Option

- **Hex Head Stem**
To order, add designator - HS as a suffix to the basic part number.
Example : BLV - 8N - HS
- **Barbed Vent Tube**
To order, add designator - B as a suffix to the basic part number.
Example : BLV - 8N - B

Caution When installing a Hy-Lok bleed valves, the vent tube should be positioned not to influence the fluid system on operators. Be sure that bleed valves should be always slowly opened in order to protect operators from exposure to hazardous system fluids.

How To Order

Use S316 for 316 stainless steel or STEL for carbon steel, MONE for alloy 400 as a suffix to the basic part number.
Example : BLV - 4N - S316