



Valves, Automation & Controls

# Fig. OP50CE6DV OIL PATCH CARBON STEEL BALL VALVE

## Design Features

- Carbon Steel Body
- 5000 psi
- Full Port
- 2 Piece
- Delrin Seats
- Nace MR-01-75-2009 Compliant
- Heavy Duty Locking Device
- Blow-out Proof Stem
- Double O-Ring Stem Seal
- Grease Fitting for Constant Lubrication and Protection Against Corrosion and Moisture

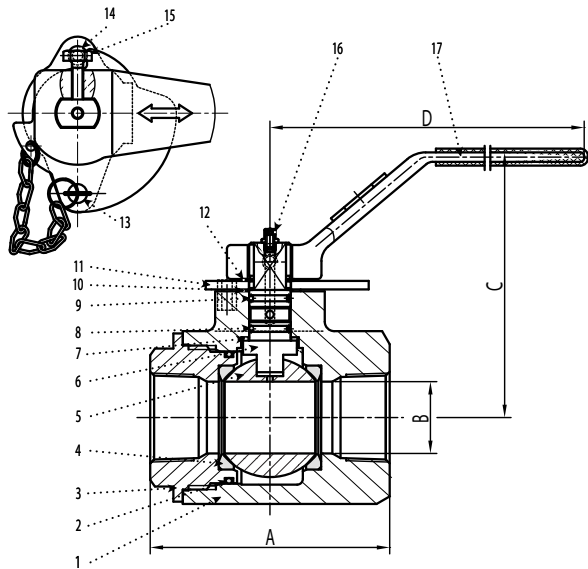

No.	Part	Material
1	Body	WCB
2	Body Seal	Viton
3	Bonnet	WCB
4	Seat	Delrin
5	Ball	AISI 420 Stainless Steel
6	Stem	AISI 420 Stainless Steel
7	Thrust Washer	PTFE
8	Stem Seal	Viton
9	Stem Seal	Viton
10	Stem Packing	PTFE
11	Locating Plate	Steel
12	Clip Spring	Spring Steel
13	Pin with Chain	Copper & Steel
14	Handle Screw	Steel
15	Stop Bolt	Steel
16	Grease Zerk	SS201
17	Handle	Ductile Iron

Size IN	Part Number	Weight LB	A IN	B IN	C IN	D IN
1	SVOP50CE6DV010	4.6	4.03	1.00	3.39	6.65

## Technical Information

Pressure Temperature Ratings

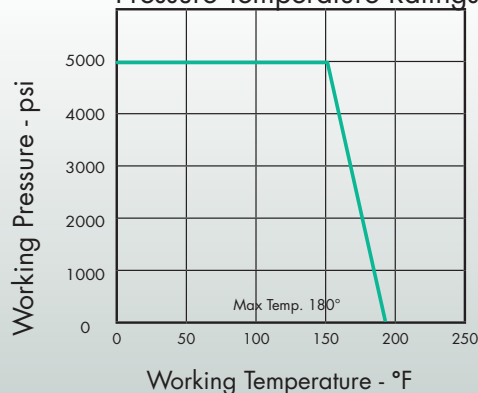

USA 800-766-0076

Fax 323-890-4456

www.smithcooper.com

www.sharpevalves.com

Los Angeles, CA

Chicago, IL

Atlanta, GA

Vancouver, WA

Houston, TX